

# UNIVERSAL CYLINDERS

double-acting, pmax. 500 bar

## Description:

With the double-acting universal cylinder, variable work piece sizes can be processed in one fixture. Because of the design, this cylinder can be used either as a stroke cylinder or a clamping cylinder.

The universal cylinder is equipped with a stable safety ring. It can thus be installed into a through-bore of the fixture body. The mouthing depth can thereby be adjusted in two stages.

For the purpose of supplying pressure oil, the double-acting cylinder is equipped with threaded ports. The connection can be either axial or radial. Depending on the type of connection, the locking screws may need to be exchanged.

In order to prevent the penetration of shavings and liquids, the piston glides through a soft wiper made of polyurethane. Contact bolts, for instance, may be attached to the internal thread of the piston.

The universal cylinder is suitable for temperatures between -40°C and +80°C.

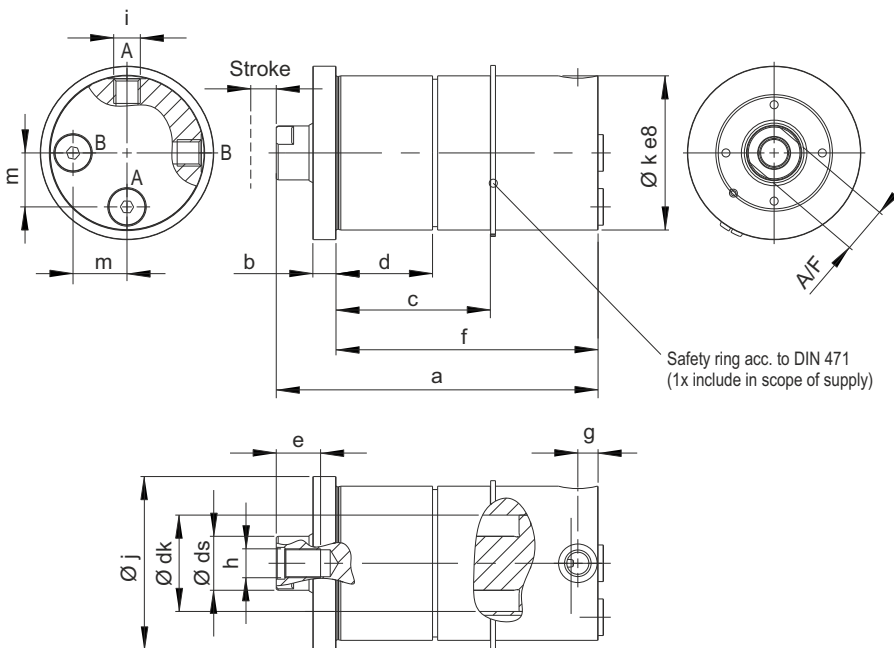

## Technical data:

dk Ø Piston	[mm]	25	32	40	50	63	
ds Ø Rod	[mm]	14	18	22	28	36	
Stroke ± 1	[mm]	32	40	50	64	64	
Clamping force at 100 bar	[kN]	4,9	8	12,5	19,6	31,1	
Clamping force at pmax.	[kN]	19,6	32	50	78,4	124,4	
Tensile force at 100 bar	[kN]	3,3	5,5	8,7	13,5	21	
Tensile force at pmax.	[kN]	13,2	22	34,8	54	84	
Oil req./mm stroke, piston	[cm³]	0,5	0,8	1,3	2,0	3,1	
Oil req./mm stroke, rod	[cm³]	0,4	0,6	0,9	1,4	2,1	
a	[mm]	122	133	147	167	186	
b	[mm]	10	10	12	12	15	
c	[mm]	65,1	70,1	80,1	80,1	100,1	
d	[mm]	45,1	45,1	50,1	50,1	60,1	
e	[mm]	12	16	18	20	20	
f	[mm]	100	110	120	136	150	
g	[mm]	12,5	12,5	10,5	10,5	13	
h	[mm]	M8	M10	M12	M16	M20	
i	[mm]	G1/4	G1/4	G1/4	G1/4	G3/8	
j Ø	[mm]	56	66	76	90	105	
k Ø	[mm]	50	58	68	80	95	
m	[mm]	14,5	18	23	28	34	
A/F		11	15	19	24	30	
Weight approx.	[kg]	1,7	2,4	3,6	5,7	8,7	
Order number:		UZY-DW...	-025-032-003	-032-040-003	-040-050-003	-050-064-003	-063-064-003
Seal kit (spare part)		DS-UZY-DW...	-025-032-003	-032-040-003	-040-050-003	-050-064-003	-063-064-003
Safety ring (spare part)			7050-001	7058-001	7068-001	7080-001	7095-001

Contact bolts for universal cylinders can be found as an accessory on the data sheet 1000-1.



Webcode: 022003

We also design and manufacture special designs

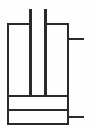

## Materials:

- ⊗ Housing: machining steel, burnished
- ⊗ Piston: hardened steel
- ⊗ Sealings: PTFE/bronze, PU, NBR

## Advantages:

- ⊗ Threaded connections, axial and radial
- ⊗ Suitable for changing workpieces sizes
- ⊗ Any installation position possible
- ⊗ Adjustable built-in depth
- ⊗ Easy to replace

## Application example:

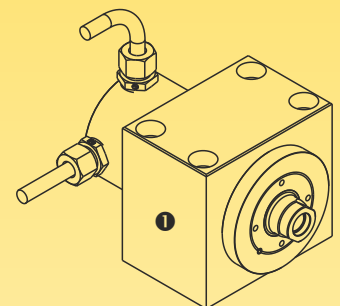

1 Cylinder fixture (not include in scope of supply)

**HYDROKOMP®**  
Hydraulische Komponenten GmbH

Siemensstraße 16, 35325 Mücke (Germany)  
Phone: +49 6401 225999-0  
Fax: +49 6401 225999-50  
E-mail: info@hydrokomp.de  
Internet: www.hydrokomp.de